

# Antennas

**W**hat is the easiest rotatable beam antenna to build? The cubical quad! What is the cheapest? The cubical quad! What is the quietest? The cubical quad! What is the best? The cubical quad!

## An antenna for all reasons

Ever since we were teenaged radio amateurs back in the 1970s, we (VK6VZ and VK6LW) have had a love affair with the cubical quad. By cubical, we mean a two-element quad antenna, which is primarily made of wire in the shape of a cube and usually consisting of a driven element and a reflector, each around a full wavelength in size. Both our younger selves belonged to local radio clubs in south-east England, which didn't have much money and built quads with bamboo-cane spreaders because they were cheap for use in the annual CW and SSB National Field Days (NFD). Most of the DX to be worked on these field days lay to the east or west of us. The cubical quad, with its typical 5dB+ gain over a dipole at the same height, 74° beam width between half power (-3dB) points, 600kHz bandwidth, and front-to-back ratio of over 20dB, could be easily turned by hand 180° between these two directions. Usually no further adjustment was required.

The other good thing about the cubical quad we quickly realised was its quietness on reception, because of its closed-loop shape being naturally resistant to the static build-up occurring on humid or thundery NFD summer days. Yagi antennas are prone to this problem, and can develop very high voltages at the element tips, resulting in spectacular corona discharges from the tips in the case of high-power commercial installations. It was this issue at Radio HCJB in Ecuador in 1939 on a four-element Yagi array built for the 25m broadcast band, which resulted in large molten chunks of aluminium falling to the ground, and caused one of the HCJB engineers, Clarence Moore, W9LZX, to invent the cubical quad [1].

Kevin, VK6LW built his first cubical quad in the mid-1970s, a dual-band antenna for 15m and 10m, in a similar low-cost way for similar reasons as the above. What we describe in this column as our featured antenna is a quad which covers the same bands, but is considerably more compact than Kevin's original.

The turning radius of a cubical quad is just half that of a full-size two-element Yagi antenna, and it has a similar gain and rear rejection (or front-to-back ratio) to a three-element Yagi antenna. No expensive long lengths of telescoping aluminium tubing are needed like the latter, just wire, wooden dowels (or fibreglass rods), and a couple of pieces of aluminium or steel tube to hold it all together on a simple tubular aluminium boom. Our clubs' NFD quads were usually supported by a home-made guyed mast of a couple of pieces of scaffold pole.

Back then, as now, a cubical quad can be built for a fraction of the price of a two-element or three-element Yagi antenna if you use parts mostly bought at the local hardware store and automotive retailer. The spreaders, which hold the wire full-wave loops in place, can be made from wooden dowels, wound with electrical or duct tape to keep moisture out. These are slid into simple spreader mounts, known as 'spiders', which are made from square aluminium tube, held in place on the

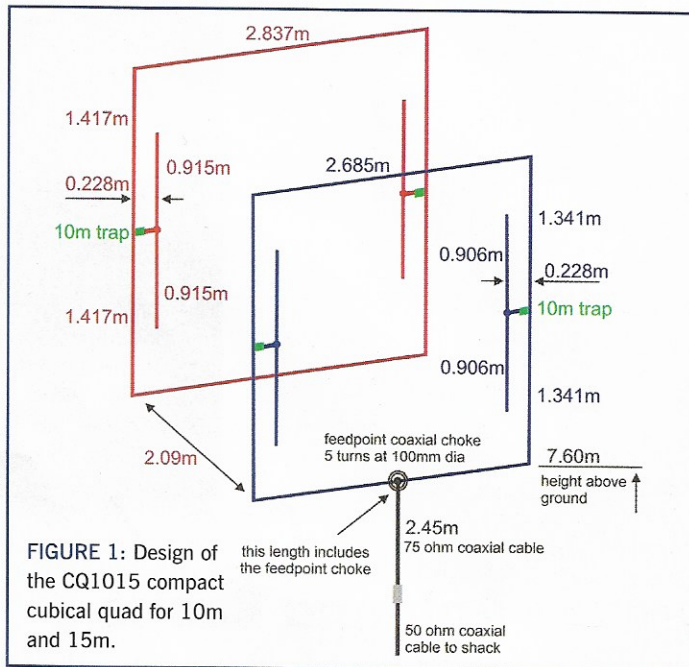

FIGURE 1: Design of the CQ1015 compact cubical quad for 10m and 15m.

quad's short aluminium boom by galvanised-steel exhaust clamps. The feedpoint insulator and the other necessary insulators needed can be made from small rectangles cut from a sheet of polycarbonate/Lexan. None of the points where the wires pass over the quad spreaders are at high voltages, so the wires can be passed through 6mm PVC reticulation tubing and fixed at the ends of the spreader by, for example, using a couple of crossed-over stainless-steel cable ties.

## Quad misconception

Another important attraction of a cubical quad is that it is a forgiving antenna. If an HF Yagi antenna's elements are a couple of centimetres too big or too small, it can affect its performance significantly. In contrast, as long as the cubical quad's reflector is roughly 3 to 5 per cent larger than the driven element, even if you are a couple of centimetres

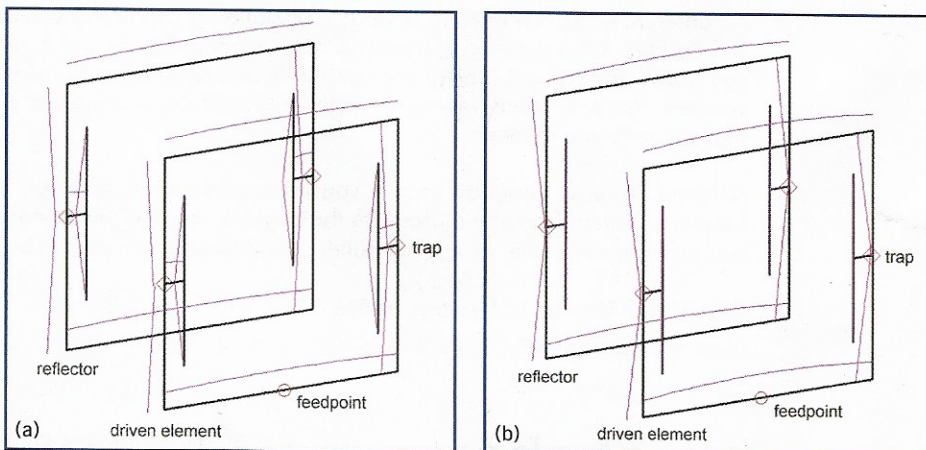

FIGURE 2: The current distribution in the CQ1015 cubical quad on (a) 15m and (b) 10m.

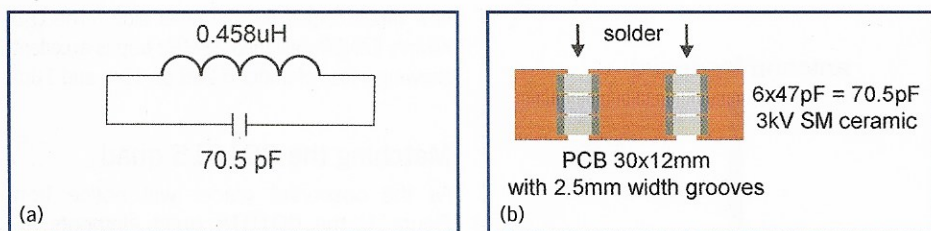

FIGURE 3: (a) the circuit diagram of 28.0MHz trap, and (b) the mechanical construction of the trap capacitor.



FIGURE 4: Construction of the 28.0MHz trap.

out in the two loops' circumferences and the VSWR might be slightly high, the quad's gain and radiation pattern will be preserved. Owing to the way some of the original articles on cubical quads were written, there is a long-standing misconception that quads require careful tuning, involving the use of a specialised, shorted stub placed in the lowest wire of the reflector. Nothing could be further from the truth.

The reality is that the use of this stub actually made the tuning harder. Radio amateurs would move the stub's shorting bar up and down, tuning for maximum front-to-back ratio/minimum signal on a received signal, and find its position made very little difference, so thought there was something wrong with the antenna! In fact, the quad is so broad in its tuning that you can vary the reflector loop in size all the way from three to five per cent larger than the driven element and, while it may affect the front-to-back ratio slightly, there will be no practical effect on the forward gain (the important bit) of the antenna. As EZNEC can show, if a cubical quad's reflector couples well-enough with the driven element to show a front-to-back ratio of as little as 10dB, this is nevertheless enough for the antenna to produce its maximum forward gain.

To sum up, tuning stubs on a conventional cubical quad are totally unnecessary and we have never used them.

### A reduced-size quad

Both of us have widely experimented with reducing the size of quad and delta-loop beams over the last 30 or so years. In our experience, one of the lesser-known facts about cubical quads is they can be simply miniaturised, without using potentially-lossy loading coils, down to about three-quarters size but retaining a similar performance to full-size. This is achieved by using capacitive loading, in the form of capacity hats (or arms) which are connected to the driven element and reflector loops at their highest-voltage points. There are two capacity hats per element, each consisting of two wires that run parallel to the wire loop which forms the element. By carrying out the electrical lengthening at the lowest current points in the quad loops using the capacity hats, this causes the least possible losses in the miniaturised antenna.

Our interest in the possibilities of this form of mini-quad go back almost fifty years to an article by Ron Stone, G3YDX/GW3YDX (SK), in *RadCom*, who had used this technique to build a miniature 20m cubical quad to use from his north-London home [2]. Ron reckoned the gain of his quad was only around 0.5dB less than a full-sized one. Inspired by this and earlier work by David Courtier-Dutton, G3FPQ, who built a mini 80m quad [3], Steve, VK6VZ scaled-down G3FPQ's design to build a 40m mini-quad. This was the best 40m antenna Steve has ever had, and got him close to

the all-time Australian record in the CQ WW CW contest, held by Kevin.

So the capacitively-loaded quad *really* works! But there's more! At this high point of the solar cycle, Kevin has decided to design a two-band 15m/10m cubical quad for *RadCom* readers, which would fit into the footprint of a single-band 10m one (Figure 1). He recalled a commercial 20/15m design by Eric Jolliffe, G3IMX using capacity-hat loading to get a 15m quad to resonate on 20m. G3IMX had inserted a high-impedance 21.0MHz parallel LC trap at the junction between the quad loops and the capacity hats, cleverly making a dual-band 20/15m antenna. This meant the whole of each loop (including the capacity hats) were self-resonant on 20m, but a 15m signal was isolated from the hats by the traps, making the loops self-resonant on the latter band.

Kevin's 'CQ1015' cubical-quad design works in a similar manner, with the driven element and reflector having the same dimensions as a 10m quad, but with capacity hats (isolated by 28.0MHz traps) being used to resonate the antenna on 15m. As we shall discuss later, the quality of the 28MHz traps is the key to the success of the CQ1015. To give a better idea of how the CQ1015 works in practice, Figure 2(a) and Figure 2(b) show the CQ1015 current distributions on 15m and 10m respectively.

### Making a better mouse-trap

Parallel-tuned LC traps are now more efficient than when G3IMX designed his quad, owing to the invention and ready availability of ceramic and porcelain-substrate surface-mount (SM) capacitors. Kevin uses several 3kV-rated ceramic SM capacitors in a series-parallel configuration in each of the four lightweight CQ1015 traps (Figure 3(a))

Steve Ireland, VK6VZ/G3ZZD,  
and Kevin Smith, VK6LW/VK6T/  
ex-G4EHF  
stevevk6vz@tpg.com.au

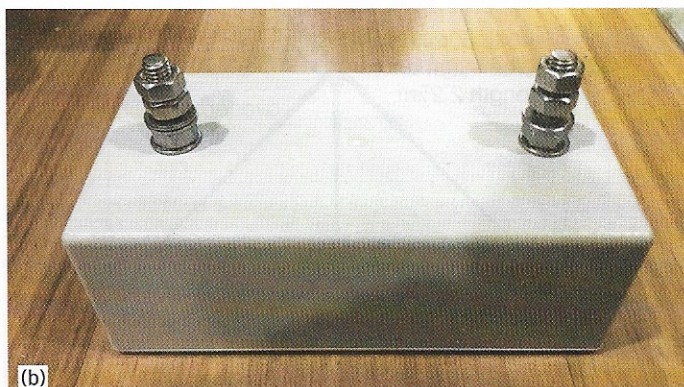
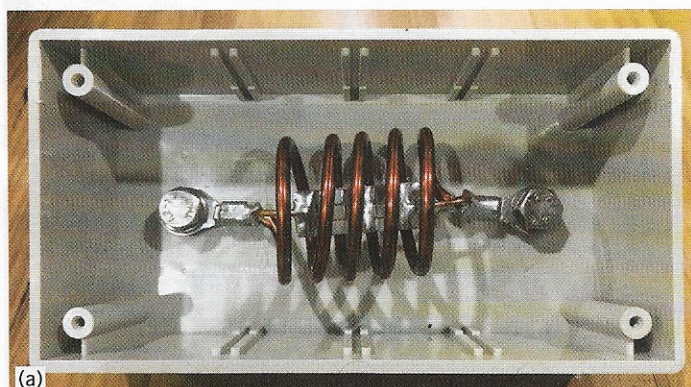

FIGURE 5: (a) mounting the MHz trap in a polycarbonate box, (b) external connections.

and Figure 3(b)). The 47pF SM capacitors (Mouser part 581-1812HA470JAT2A) are mounted on a 30mm x 12mm rectangle of bare PCB inside the coil (Figure 4). This configuration makes the trap capacitors capable of withstanding 6kV. Their current capability should allow operation at the UK legal power limit of 1kW.

The coil has a diameter of 30mm, is 35mm in length, and is made from five turns of 3mm diameter copper wire. To make the capacitors, two 2.5mm-wide vertical grooves are cut into the copper layer of each piece of the PCB, down to the fibreglass base, using a hacksaw (and ideally a Dremel-type tool). Three of the 47pF capacitors are soldered across each groove, using 0.5mm solder plus some extra flux from a flux pen to make the solder flow easily. The resulting (series-parallel) trap capacitor is then soldered to the trap coil using short pieces of 1mm bare copper wire from each end of the capacitor. The trap assemblies are mounted in small polycarbonate boxes, with two M6 x 30mm stainless-steel bolts being used to connect the trap between the antenna loops and the capacity hats (Figure 5(a) and Figure 5(b)).

You now need to tune the traps using an antenna analyser or Nano VNA. If you have built the coil to the Kevin's specifications, you should probably get within a few hundred kHz of 28.0MHz. To lower the trap's resonant frequency, compress the turns of the coil. To raise the frequency, open the turns.

It is important to note that Kevin spent a lot of time designing these traps, optimising the inductance-to-capacitance ratio, and then developing their practical implementation. The ceramic SM capacitors are superior to old-style silver mica capacitors, in particular in terms of their very-small equivalent series resistance. We strongly recommend you build the traps with the capacitors specified if you want to get the best results. As WA2000 says on his excellent website [4] in a section devoted to antenna trap loss: "With traps the big buzzword is 'Q'. The higher the Q the more efficient the trap is. Well-built antenna traps are of high-Q design, and these should only have a loss of 0.1 to 0.2dB per trap versus a full length antenna radiator. The Q is the amount of electrical energy that comes into the trap versus

how much comes out the other side." The Q of Kevin's EZNEC-designed 28MHz trap is excellent, showing a loss of under 0.2dB on 15m and 10m.

### Matching the CQ1015 quad

As the observant reader will notice from Figure 1, the CQ1015 quad elements are spaced just over 0.125 wavelength on 15m, the optimum spacing for a cubical quad. The spacing is about 0.2 wavelength on 10m, but this will still give excellent forward gain and front-to-back ratio. However, the differences in spacing on the two bands means the feed impedances will be different. As a result, Kevin has designed a single coaxial-cable transformer to present a good match to a 50Ω RG-213/LMR-400/LL-500 coaxial cable on both bands (Figure 6). This consists of 2.45m of RG-11 coaxial cable, which is then crimped or bolted between the quad feed-point and the 50Ω coaxial feeder.

A feed-line choke is formed by winding five turns of the coaxial transformer on a 100mm former, removing the former, and keeping the choke turns in place by wrapping them with UV-resistant duct tape (or similar). The use of the feed-line transformer means that the CQ1015 quad should show a VSWR of 1.3:1 at 21.0MHz, slowly falling to 1.2:1 at 21.4MHz. On 10m, EZNEC shows a VSWR of 1.3:1 at 28.0MHz, slowly rising to 1.8:1 at 28.5MHz.

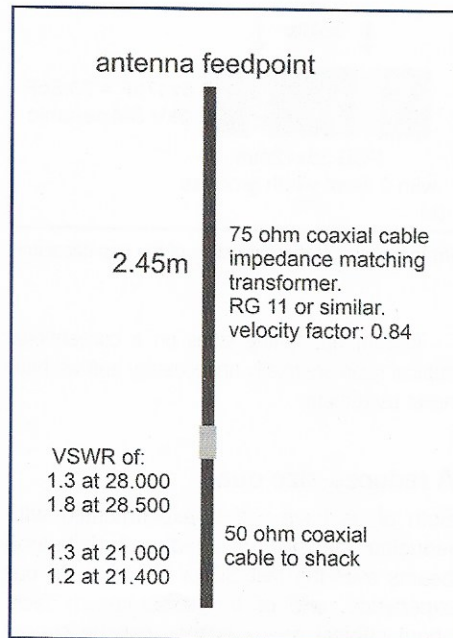

FIGURE 6: Coaxial matching transformer for the CQ1015.

### Construction

If you have good basic DIY skills, building the two CQ1015 elements should be straightforward (Figure 7). However, it is one of those situations where sometimes four hands are better than two. We suggest you find a friend to give you a hand, maybe someone else who is also interested in building a quad?

Before starting construction, we also recommend downloading and looking through a copy of *All About Cubical Quad Antennas* by William Orr W6SAI and Stuart Cowan W2LX [5]. This is the classic book about quad construction, with lots of photos and diagrams which give ideas and guidance about every aspect of quad construction. The two CQ1015 elements should be mounted on a boom made of 40 to 50mm aluminium round tube, with a wall thickness of around 2mm. The simplest and cheapest way to make the spreaders is to use 16mm diameter 2m long wooden dowels, covered in a layer of spirally-wound Scotch™ electrical tape. Use Scotch tape, not the cheaper brands, as the glue usually fails in

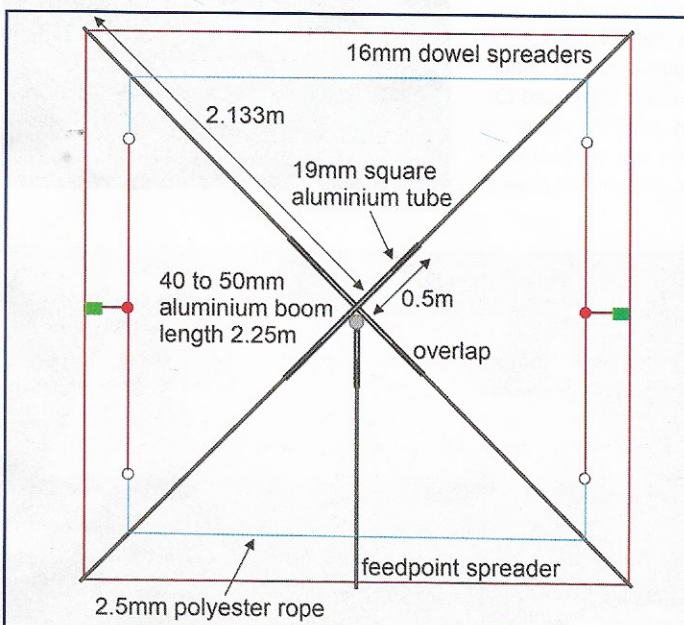

FIGURE 7: Mechanical construction of CQ1015 elements.

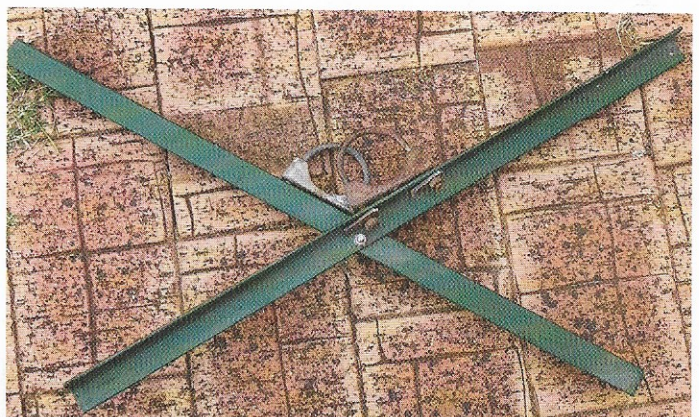

FIGURE 8: How the element spiders are attached to the boom.

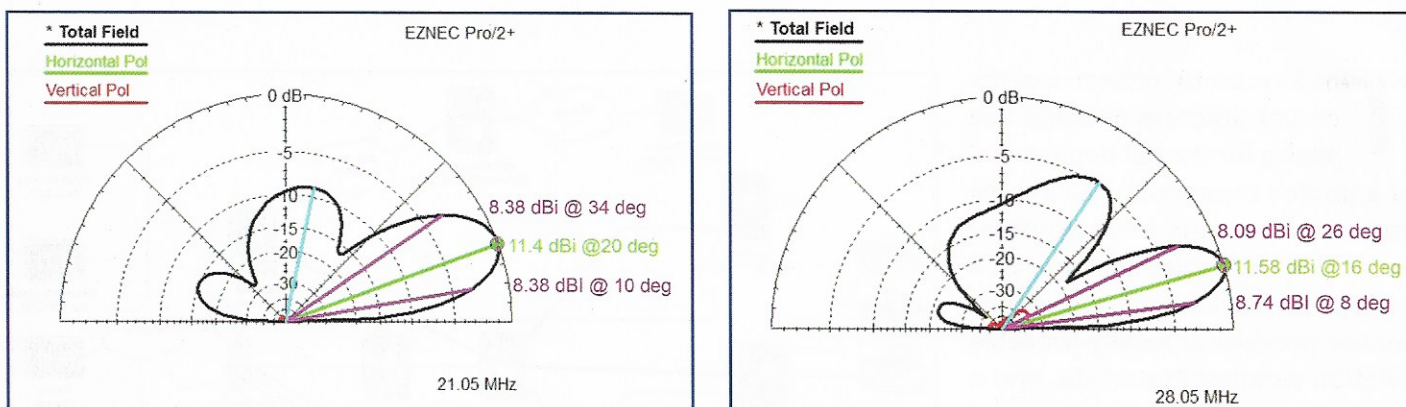

FIGURE 9: The elevation radiation patterns of the CQ1015 on (a) 15m and (b) 10m.

the summer heat and your quad ends up looking like a maypole.

Each quad-loop spider centre is made from two 1m lengths of 19mm square aluminium tube. The tape-coated 16mm diameter dowel spreaders should be a firm 'push-fit' into the square aluminium tube. Adjust the lengths of the dowels inside the central aluminium tube until each spreader half has a length of around 2.2m from the boom. Each corner of a quad loop is mounted about 2.133m down each spreader half; the extra length is needed so the loop corners can be fixed in place, using crossed-over stainless-steel cable ties (there's more of how to do this later). Once you have fixed the spider/spreader overlap length, put an appropriately-sized stainless steel jubilee clip around each dowel spreader where it meets the spider. This is to prevent the spreader being pushed inside the spider once tension is placed on it.

The spiders are held in place on the boom by galvanised-steel (or stainless-steel) muffler clamps which are of a diameter to suit your particular boom. The spiders are drilled around their central point to take the muffler clamps in such a manner that the clamps overlap and hold the spiders tightly to the boom at right angles to each other. Figure 8 illustrates how this overlap is done (on an early VK6LW spider made from angle iron). The feed-point spreader/support is made in a similar fashion to the other spreaders, using one muffler clamp to hold it in place.

Once you have built the framework of each quad loop, it is the time to build the loops themselves. Steve likes to build the loops after the element spiders are mounted on the boom, but others may find it easier to build the loops on the ground or a workbench and then add them to the boom.

The driven element and reflector loops, and the associated capacity hats, are made from bare 2mm aluminium (electric fence) stranded or hard-drawn copper (Copperweld) wire. The dimensions of the capacity hats are quite critical, within a few millimetres, in order to get excellent performance on 15m. This is definitely a case of 'measure twice, cut once'.

Each loop is run through four 20cm-long

pieces of 6mm-diameter PVC reticulation tube. These are each slid around to one of the four loop corners and held in place on the quad spreaders, using the aforementioned crossed-over stainless steel cable ties. The capacity hats are run parallel to the loops and attached to the dowel spreaders by lengths of 2.5mm diameter polyester (Dacron) rope, with insulators made from small pieces of polycarbonate/Lexan used at the ends of the capacity hats. The ropes, shown in blue in Figure 7, also serve to act to brace the spreaders.

In terms of a support for your quad, a mast/rotator that is capable of supporting/turning, say, a VHF 10-element Yagi antenna should do the job. As we said early on in the article, the 'armstrong' method of rotation works well with this antenna. You will also need a boom-to-mast clamp, and one from a scrap tri-band HF Yagi is ideal. Another possibility is to do what Steve once did with a full-size 20m cubical quad. He suspended it under the canopy of a tree, using a 10mm Dacron halyard [6].

### Performance

The CQ1015 is mounted at a boom height of about 9m agl, in order to take advantage on both 15m and 10m of the extra W3LPL-described ground gain (caused by reflection from the Earth) of 5dBi which occurs when an antenna is about a half-wave above ground [7]. Kevin used EZNEC to determine the best compromise in terms of maximising the ground gain on both bands.

As a result, at this height, the CQ1015 shows a maximum gain on 15m of 11.4dBi at an elevation angle of 20° (Figure 9(a)). In contrast, on 10m, where the CQ1015 is a full-sized cubical quad, it has a maximum gain of 11.58dBi at 16° (Figure 9(b)). On both bands, the front-to-back ratio is about 20dB, similar to a full-size mono-band quad.

### Conclusions

The CQ1015 cubical quad offers excellent performance on 15m and 10m, approaching

that of a 3-element full-sized Yagi antenna. As described, it can be built cheaply, mostly using parts from your local hardware and automotive store, over a weekend or two. You can hide it away behind a tree (or under a tree) and it offers seriously competitive performance in a contest or DXing. Steve has used two-element cubical quads and the equivalent delta-loop antenna for most of the last 30 years. He has also used a wide-spaced 3-element single band Yagi antenna (on 20m), and preferred the quad for its ability to offer a consistently-lower atmospheric noise level, broader beam width, less critical dimensions, and lighter weight.

### References

- [1] [5] 'All About Cubical Quad Antennas' by William Orr W6SAI and Stuart Cowan W2LX. Download from: <https://sp5ppk.waw.pl/wp-content/uploads/2018/08/AllAboutCubicalQuadAntennas.pdf>
- [2] 'Practical Design for a Top-hat Loaded 14MHz Miniquad' by RGD Stone, G3YDX, *RadCom* October 1976. Also published in 'HF Antennas for All Locations' By Les Moxon, G6XN, page 207, 2<sup>nd</sup> Edition, RSGB Publications 1993
- [3] ON4UN's Low-Band DXing, published by the ARRL 2005 (3<sup>rd</sup> edition, chapter 10-14, section 3.2 Reduced-Size Loops, Figure 10-21 ). If you have the 2<sup>nd</sup> edition, this has more constructional information about the G3FPQ 80m quad
- [4] <https://www.wa2000.com/yagistrikesback.html>
- [6] Bi-Directional Quad for Few Pounds by Steve Ireland, VK6VZ, *RadCom* October 1998. Also in The Antenna File, edited by Mike Dennison G3XDV, RSGB Publications 2001
- [7] <https://www.contestuniversity.com/wp-content/uploads/2021/01/2-W3LPL-CTU-2017-How-to-Improve-your-Transmitting-Antennas-for-Low-Solar-Activity.pdf>